

ORION STEEL VALVES
Globe Valves
BS 1873

**GLOBE VALVES BS 1873 - p. 41**

Class ANSI 150 (PN 20) • 300 (PN 50) • 600 (PN 100)
900 (PN 150) • 1500 (PN 250) • 2500 (PN 420)

ANGLE GLOBE VALVES BS 1873 - p. 48

Class ANSI 150 (PN 20) • 300 (PN 50) • 600 (PN 100)
900 (PN 150) • 1500 (PN 250) • 2500 (PN 420)

Y PATTERN BOLTED BONNET BS 1873 - p. 52

ORION STEEL VALVES
Globe Valves
BS 1873

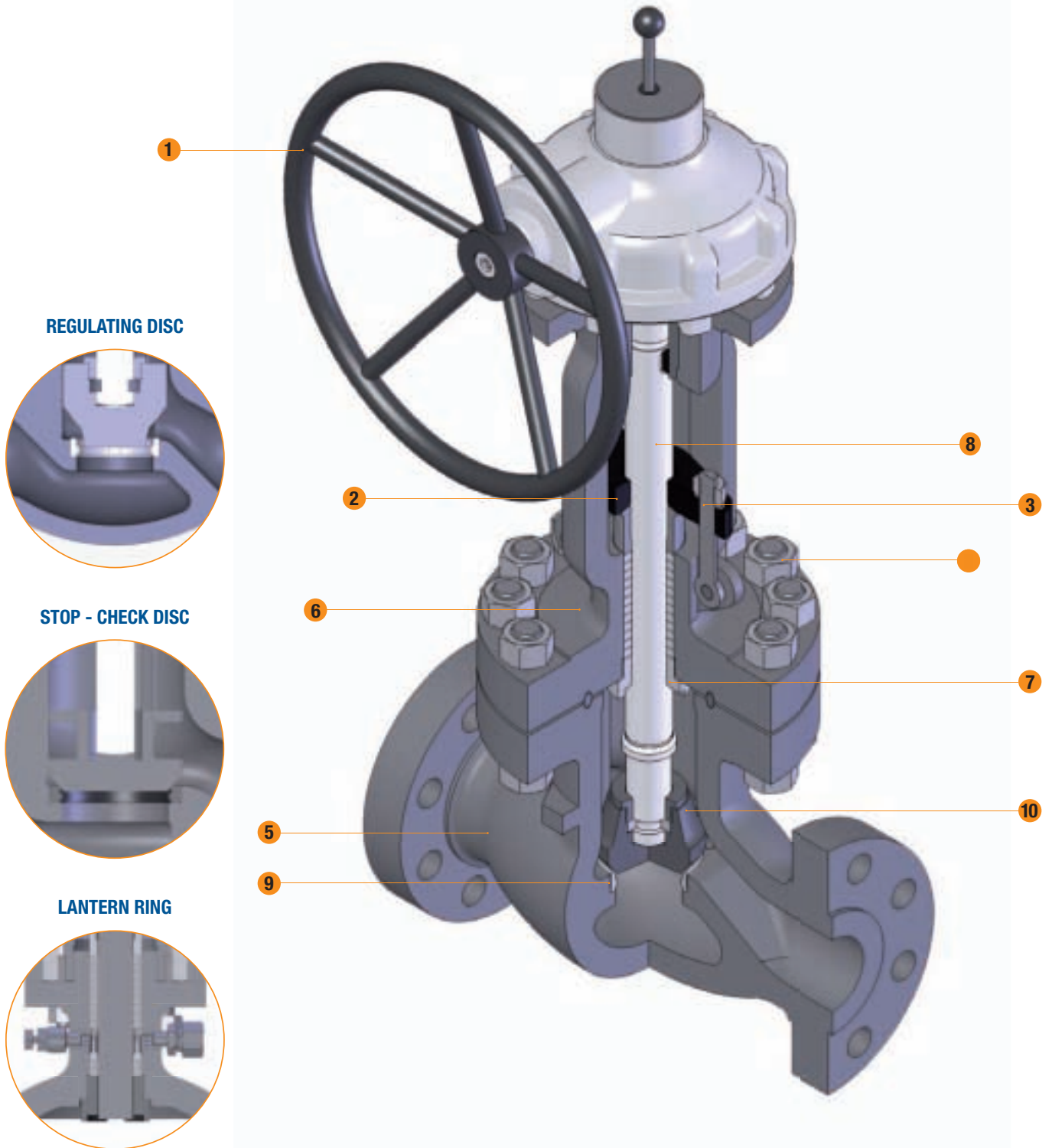

CAST STEEL BODY, OUTSIDE SCREW AND YOKE, RISING STEM, NON-RISING OPERATOR, RENEWABLE SEATS, REMOVABLE YOKE SLEEVE, BACKSEAT FOR REPACKING UNDER PRESSURE.

- 1 OPERATOR** The spoked handwheel is fabricated from steel pipe. The hub is coupled to the yoke sleeve by means of a key. Larger valves are equipped with a bevel or spur gear gearbox unit.
- 2 GLAND AND FLANGE** They are in forged steel and are supplied in two pieces, self aligning design in order to allow the gland to slide parallel to the stem even if the eyebolts are unevenly tightened.
- 3 GLAND BOLTS AND NUTS** The forged steel gland bolts are of the eyebolt type which can be swung outward for ease of gland repacking. They are fixed to the bonnet by hinge pins.
- 4 BONNET BOLTING** Bonnet studs and nuts are manufactured from alloy steel to the relevant ASTM standard. The body to bonnet connection is designed according to ASME VIII DIV 1 standard.
- 5 BODY** The body is in carbon or stainless steel and is also available in many other CRA. It is carefully designed for total reliability and simple maintenance. The basic dimension, i.e. wall thickness, face to face and flanges comply with the relevant BS and ASME standards. The body-to-bonnet flange is circular. The body-to-bonnet joint are male-and-female on Class 150 and 300 and ring joint on Class 600 and above. The body is basically supplied with renewable seats. Bosses are provided for draining connections. The internal surfaces in contact with the fluid can be fully lined or clad (for larger sizes only) for improved corrosion or erosion resistance.
- 6 BONNET** As the body, the bonnet is in carbon or stainless steel and is available in many other CRA. It is machined to accept yoke sleeve and incorporates a stuffing box sized in accordance with the BS standard. Lifting lugs can be provided integrally cast on the bonnet surface.
- 7 BONNET BUSHING** The bonnet bushing or backseat is part of the valve trim. Its design allows valve repacking without valve's bleeding or draining. Hardfacing can be provided on stem seating surface.
- 8 STEM** The stem is part of the trim and is available in a wide range of material in accordance to BS1873, API 600 or customer's requirements. The stem is provided with a ground backseat in order to ensure a perfectly tight seal to the stuffing box when the valve is fully open. The stem is highly finished in order to minimize friction and prevent damage to the packing. The thread is trapezoidal ACME type. All the stem sizes comply with the BS 1873 standard.
- 9 SEAT RING** Threaded and seal-welded seat ring is supplied as a standard. The seats are part of the trim of the valve. They can be simply threaded for easy installation and dismantling. Special attention is given to the seating surface which is ground and lapped for a tight seal.
- 10 DISC** The disc is the main part of the trim. It is connected to the stem by means of a swiveling half rings coupling and is guided in the body from 4" and above. The standard sealing profile is a spherical surface seating against a conical seat. If required a conical to conical seating can be supplied, and for flow throttling operations a regulating disc is adopted, shaped in order to give a linear opening. The stop check execution shows an externally guided disc, disconnected from the stem. A cladding or lining can be applied to larger discs to improve its resistance against erosive and corrosive environments.
- REMARKS** A lantern ring is supplied upon request, in this case the stuffing box shall be drilled, tapped and fitted with an 1/4" NPT plug or grease fitting.
- INSTALLATION REMARKS** Globe valves are best fit for vertical stem / horizontal flow installation. Special cases can be evaluated and developed on request.

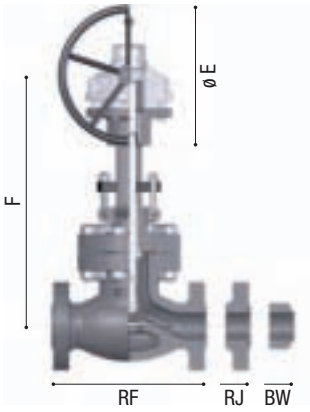

Class ANSI 150 (PN 20)

FIGURE NUMBERS - CLASS ANSI 150 - ALL SIZES

GL 150: RF - RAISED FACE • GL 150 BW - WELDING ENDS

SIZE	2"	2½"	3"	4"	5"	6"	8"	10"	12"
RF-BW	203	216	241	292	356	406	495	622	699
C-closed	385	420	455	525	595	655	750	890	1.080
D-open	417	433	475	545	615	740	840	1.005	1.210
E	200	200	250	250	350	BG	BG	BG	BG
F	/	/	/	/	/	650	787	924	1.062
Approximate WEIGHT (Kg)									
FLANGED	25	32	42	65	86	115	168	313	465
BW	20	26	34	55	73	100	149	287	425

SIZE	14"	16"	18"	20"	22"	24"	26"	28"	30"
RF-BW	787	914	950	978	1.067	1.295	1.295	1.448	1.524
C-closed	1.180	1.190	1.340	1.365	1.550	1.730	1.880	2.050	2.200
D-open	1.330	1.360	1.530	1.515	1.740	1.970	2.140	2.310	2.480
E	BG	BG	BG	BG	BG	BG	BG	BG	BG
F	1.199	938	1.251	1.356	1.460	1.564	1.669	1.773	1.878
Approximate WEIGHT (Kg)									
FLANGED	688	910	1.063	1.214	1.365	1.516	1.667	1.818	1.969
BW	634	841	993	1.123	1.253	1.383	1.513	1.643	1.773

Class ANSI 300 (PN 50)

FIGURE NUMBERS - CLASS ANSI 300 - ALL SIZES

GL 300: RF - RAISED FACE • BW - WELDING ENDS • RJ - RING JOINT

SIZE	2"	2½"	3"	4"	5"	6"	8"	10"	12"
RF-BW	268	292	318	356	400	445	559	622	711
RJ	284	308	334	372	416	461	575	638	727
C-closed	635	683	730	780	830	880	980	1.080	1.180
D-open	665	723	780	839	898	957	1.074	1.192	1.310
E	200	200	350	BG	BG	BG	BG	BG	BG
F	/	/	/	578	638	698	818	938	1.058
Approximate WEIGHT (Kg)									
FLANGED	30	51	56	94	105	180	316	420	705
BW	27	42	50	75	82	150	276	363	609

SIZE	14"	16"	18"	20"	22"	24"	26"	28"	30"
RF-BW	864	914	978	1.016	1.118	1.346	1.346	1.499	1.594
RJ	880	930	994	1.035	1.140	1.368	1.372	1.524	1.619
C-closed	1.368	1.557	1.745	1.934	2.122	2.311	2.499	2.688	2.876
D-open	1.550	1.790	2.030	2.270	2.511	2.751	2.991	3.231	3.471
E	BG	BG	BG	BG	BG	BG	BG	BG	BG
F	1.178	1.200	1.221	1.243	1.265	1.286	1.308	1.330	1.351
Approximate WEIGHT (Kg)									
FLANGED	922	1.118	1.742	2.366	2.989	3.613	4.237	4.861	5.484
BW	808	975	1.556	21.38	2.719	3.300	3.881	4.463	5.044

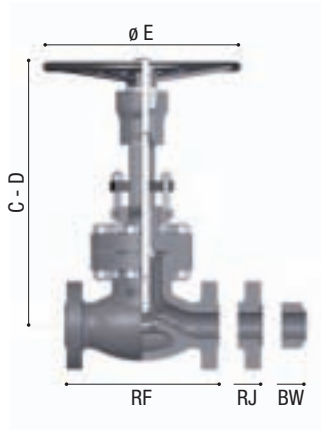
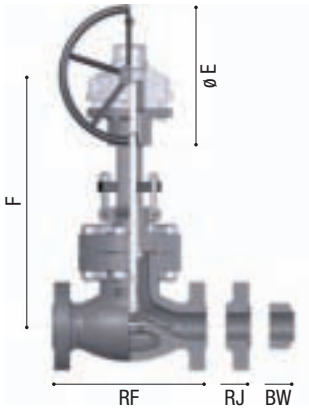

Class ANSI 600 (PN 100)

FIGURE NUMBERS - CLASS ANSI 600 - ALL SIZES

GL 600: RF - RAISED FACE • BW - WELDING ENDS • RJ - RING JOINT

SIZE	2"	2½"	3"	4"	5"	6"	8"	10"	12"
RF-BW	292	330	356	432	508	559	660	787	838
RJ	295	333	359	435	511	562	663	790	841
C-closed	445	496	548	650	731	813	975	1.138	1.300
D-open	485	544	603	720	809	898	1.075	1.253	1.430
E	250	300	BG	BG	BG	BG	BG	BG	BG
F	/	/	594	695	797	898	912	1.065	1.218
Approximate WEIGHT (Kg)									
FLANGED	40	64	78	133	237	284	578	630	1.010
BW	32	54	65	113	191	230	502	515	856

SIZE	14"	16"	18"	20"	22"	24"	26"	28"
RF-BW	889	991	1.092	1.194	1.295	1.397	1.448	1.600
RJ	892	994	1.095	1.200	1.305	1.407	/	/
C-closed	1.402	1.500	1.606	1.708	1.810	1.910	2.014	2.116
D-open	1.555	1.680	1.805	1.929	2.054	2.179	2.304	2.429
E	BG	BG	BG	BG	BG	BG	BG	BG
F	1.371	1.523	1.676	1.829	1.982	2.134	2.287	24.40
Approximate WEIGHT (Kg)								
FLANGED	1.500	1.804	2.108	2.415	2.716	3.020	3.324	3.628
BW	1.345	1.584	1.823	2.062	2.301	2.540	2.779	3.018

Class ANSI 900 (PN 150)

FIGURE NUMBERS - CLASS ANSI 900 - ALL SIZES

GL 900: RF - RAISED FACE • BW - WELDING ENDS • RJ - RING JOINT

SIZE	2"	2½"	3"	4"	5"	6"	8"	10"	12"
RF-BW	368	419	381	457	559	610	737	838	965
RJ	371	422	384	460	562	613	740	841	968
C-closed	357	428	500	643	786	930	1.216	1.282	1.347
D-open	465	535	605	746	887	1.028	1.309	1.407	1.505
E	350	BG	BG	BG	BG	BG	BG	BG	BG
F	/	621	661	741	821	901	1.061	1.221	1.357
Approximate WEIGHT (Kg)									
FLANGED	89	110	120	202	330	430	723	973	1.515
BW	75	100	104	182	274	375	619	833	1.325

SIZE	14"	16"	18"	20"	24"
RF-BW	1.029	1.130	1.219	1.321	1.549
RJ	1.039	1.140	1.238	1.334	1.562
C-closed	1.413	1.478	1.544	1.610	1.741
D-open	1.604	1.702	1.800	1.898	2.095
E	BG	BG	BG	BG	BG
F	1.494	1.630	1.766	1.903	2.175
Approximate WEIGHT (Kg)					
FLANGED	3.370	4.298	5.225	6.000	8.008
BW	2.808	3.582	4.354	5.000	6.673

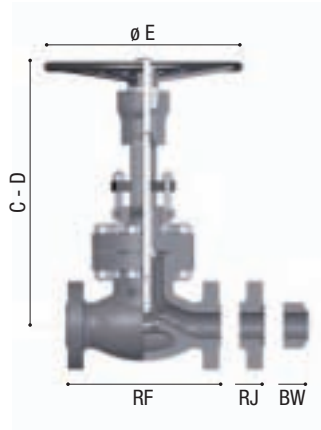
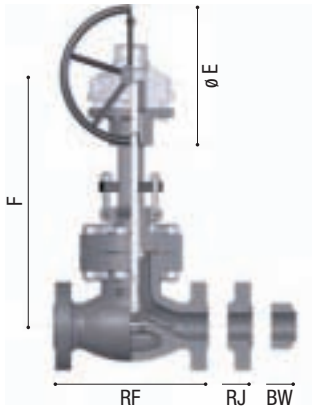

Class ANSI 1500 (PN 250)

FIGURE NUMBERS - CLASS ANSI 1500 - ALL SIZES

GL 1500: RF - RAISED FACE • BW - WELDING ENDS • RJ - RING JOINT

SIZE	2"	2½"	3"	4"	5"	6"	8"	10"	12"
RF-BW	368	419	470	546	673	705	832	991	1.130
RJ	371	422	473	549	676	711	842	1.001	1.146
C-closed	727	756	785	873	901	990	1.076	1.317	1.400
D-open	762	801	840	951	996	1.070	1.230	1.480	2.006
E	BG	BG	BG	BG	BG	BG	BG	BG	BG
F	717	762	783	895	984	1.073	1.251	1.433	1.616
Approximate WEIGHT (Kg)									
FLANGED	89	134	208	320	630	1.135	1.790	3.355	4.325
BW	75	106	172	281	543	987	1.540	2.995	3.790

SIZE	14"	16"	18"	20"	24"
RF-BW	1.257	1.384	1.537	1.664	1.943
RJ	1.276	1.406	1.559	1.686	1.971
C-closed	1.694	1.988	2.282	2.576	3.164
D-open	2.164	2.321	2.479	2.673	3.280
E	BG	BG	BG	BG	BG
F	1.798	1.981	2.163	2.345	2.710
Approximate WEIGHT (Kg)					
FLANGED	5.295	6.265	7.235	8.205	10.145
BW	4.585	5.380	6.175	6.970	8.560

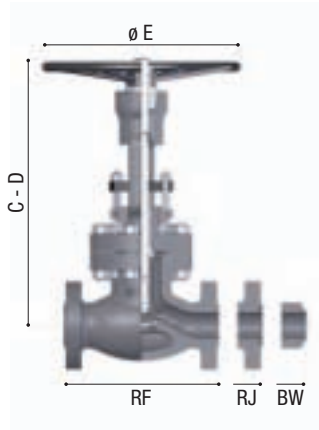
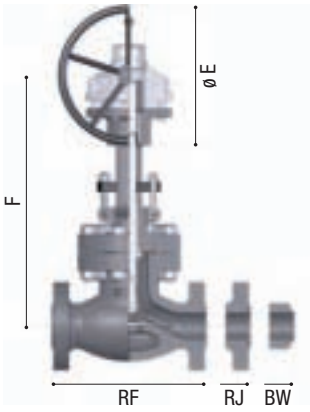

Class ANSI 2500 (PN 420)

FIGURE NUMBERS - CLASS ANSI 2500 - ALL SIZES

GL 2500: RF - RAISED FACE • BW - WELDING ENDS • RJ - RING JOINT

SIZE	2"	2½"	3"	4"	5"	6"	8"	10"	12"
RF-BW	451	508	578	673	794	914	1.022	1.270	1.422
RJ	454	514	584	683	807	927	1.038	1.292	1.444
C-closed	655	765	875	1.018	1.162	1.305	1.592	1.878	2.165
D-open	720	828	935	1.088	1.242	1.395	1.702	2.000	2.315
E	BG	BG	BG	BG	BG	BG	BG	BG	BG
F	721	828	935	1.148	1.275	1.402	1.656	1.910	2.164
Approximate WEIGHT (Kg)									
FLANGED	169	287	405	597	1.100	1.603	2.609	3.615	4.621
BW	141	245	349	515	887	1.259	2.003	2.747	3.491

SIZE	14"	16"
RF-BW	1.638	1.831
RJ	/	/
C-closed	2.452	2.738
D-open	2.622	2.928
E	BG	BG
F	2.418	2.672
Approximate WEIGHT (Kg)		
FLANGED	/	/
BW	4.235	4.979

BG: bevel gear operated.

For size and pressure classes non mentioned in the above tables please contact ORION.

N.B. All dimension are given in millimeters, weight are expressed in Kg. and are not including the operator.

Dimensions and weight may change from above values without notice.