

FOUNDATION™ Fieldbus Positioner

Type 3787



Application

Positioner for attachment to pneumatic control valves

Travels from 5 to 255 mm · Opening angle up to 120°

Bus-powered field device conforming to the FOUNDATION™ Fieldbus specification based on EN 61158-2 standard transmission technology. Integrated process controller and Link Master capability.



The microprocessor-controlled positioner compares the reference variable cyclically transmitted over the FOUNDATION™ Fieldbus network to the travel or opening angle of the control valve and produces the corresponding signal pressure output. The positioner is suitable for attachment to both linear and rotary actuators.

The Type 3787 Positioner communicates according to FOUNDATION™ Fieldbus specification with field devices, programmable logic controllers and process control systems.

An integrated PID function block allows the control of process variables required directly in the field. The shift to distributed control reduces the number of control tasks to be performed by the higher-level automation system. As a result, fewer analog inputs and outputs as well as lines are required. Thanks to the Link Master capability, autonomous closed control loops can be set up in the field.

Further benefits of the microprocessor-controlled smart positioner include:

- Operation and monitoring using bidirectional data exchange
- Automatic start-up with a multitude of application-relevant configuration options
- Monitoring and diagnosis functions
- Control parameters can be changed online
- Automatic monitoring of zero point
- Permanent storage of all parameters in non-volatile EEPROM (protection against power failure)
- Temperature and supply air effects negligible

Accessories

The digital positioner's functions can be optionally extended through the following equipment:

- Two inductive limit switches (proximity switches) · Accessible over the terminal block
- Forced fail-safe venting action · Upon absence of an external signal, the 2/2-way on-off valve (4 in Fig. 3) causes the air to be vented. Consequently, the control valve is forced to move to fail-safe position.

The venting function acts directly on the pneumatic block and remains unaffected by the output variable of the microcontroller.



Fig. 1 · Type 3787 FOUNDATION™ Fieldbus Positioner



Fig. 2 · Type 3787 Positioner with open cover

Principle of operation

The travel of the final control element is detected by the non-contact inductive travel sensor (1) and transmitted to the microcontroller (2) by a converter. In the microcontroller, the travel is compared to the set point, and the two pneumatic 2/2-way on-off valves (3, 4) are activated whenever a system deviation occurs. Depending on the deviation, these valves either supply air to (3) or vent air from (4) the pneumatic actuator via corresponding boosters.

The positioner communicates and is powered via EN 61158-2 standard transmission technology corresponding to FOUNDATION™ Fieldbus specifications.

LEDs integrated into the inside of the positioner's cover signalize the operating mode.

As a standard feature, the positioner comes with a binary input used to signalize process information via the FOUNDATION™ Fieldbus.

A write protection switch located on the inside of the cover (6) prevents saved configurations from being overwritten unintentionally.

Configuration using TROVIS-VIEW (Fig. 4)

The SAMSON configuration software TROVIS-VIEW can be used to configure the positioner. For this purpose, the positioner is equipped with an additional digital interface to be connected to the RS-232 interface of a PC. TROVIS-VIEW adapts the positioner to any process requirements and allows the process to be checked online. The control valve is linked to the process over the FOUNDATION™ Fieldbus network.

The PID function block integrated in the positioner can likewise be configured using TROVIS-VIEW. The configuration of the network connections for the PID function block is made using the NI-FBUS Configurator or a corresponding digital process control system.

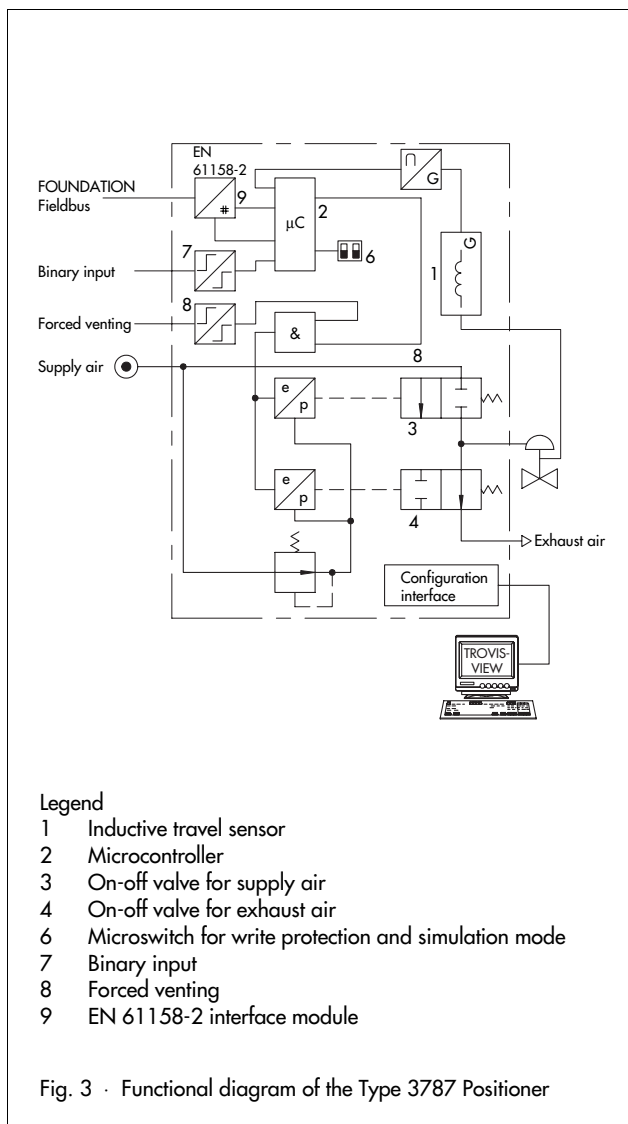

Fig. 3 · Functional diagram of the Type 3787 Positioner

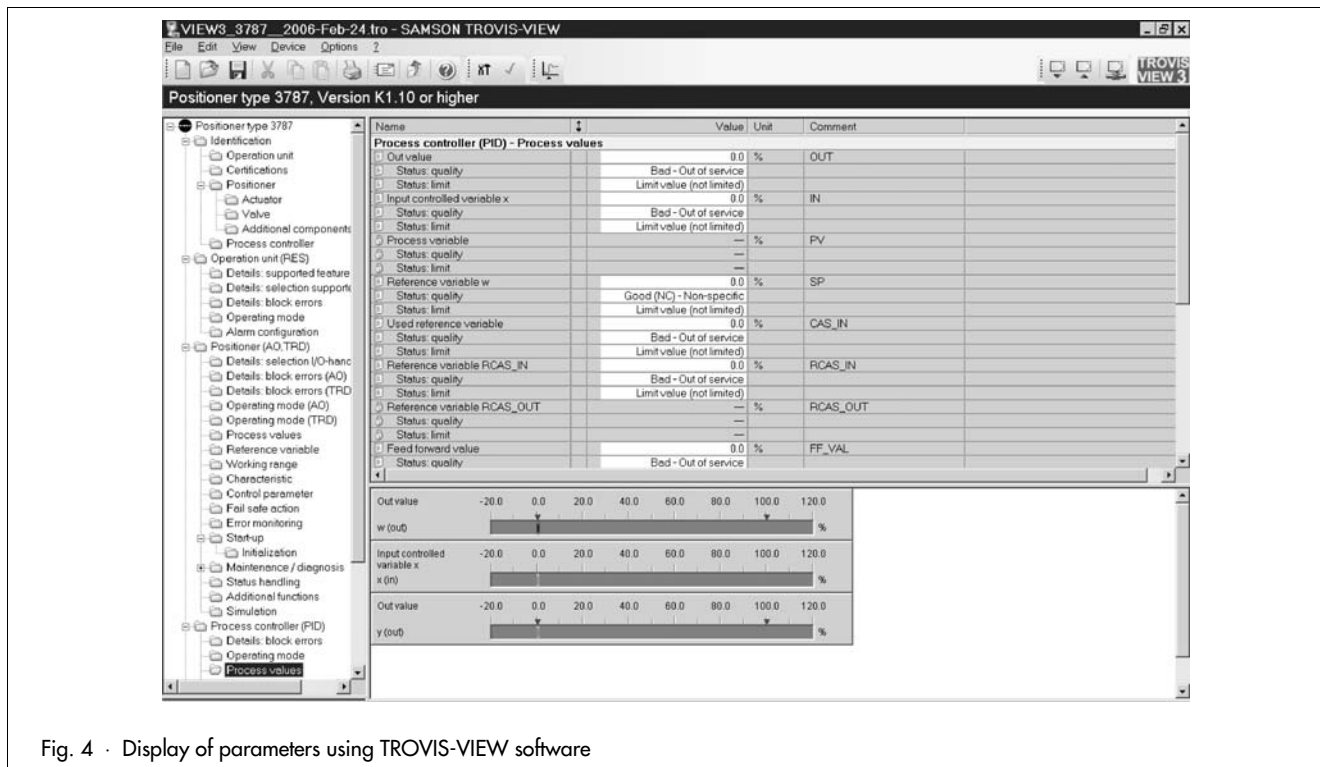

Fig. 4 · Display of parameters using TROVIS-VIEW software

Table 1 · Technical data for Type 3787

Travel Direct attachment to Type 3277 Actuator Attachment acc. to IEC 50534-6 (NAMUR)	Adjustable 5 to 30 mm 5 to 255 mm or 30 to 120° for rotary actuators
Bus connection	Fieldbus interface as per EN 61158-2, bus-powered Physical Layer Class: 113 (not explosion-protected version) 111 (explosion-protected version) Field device according to FM 3610 Entity and FISCO
Permissible operating voltage	9 to 32 V DC · Power supply over bus The limits in EC Type Examination Certificate additionally apply for explosion-protected devices
Max. operating current	13 mA
Additional current in case of fault	0 mA
Supply air	Supply air from 1.4 to 6 bar (20 to 90 psi)
Air quality acc. to ISO 8573-1 (2001)	Max. particle size and density: Class 4 · Oil content: Class 3 Pressure dew point: Class 3 or at least 10 K below the lowest ambient temperature to be expected
Signal pressure (output)	0 bar up to the capacity of supply pressure
Characteristic	Adjustable Globe valve: linear · equal percentage · reverse equal percentage SAMSON butterfly valve: linear · equal percentage VETEC rotary plug valve: linear · equal percentage
Deviation	< 1 %
Dead band (based on rated travel/angle)	Adjustable from 0.1 to 10.0 % · Cold start value: 0.5 %
Resolution (internal measurement)	< 0.05 %
Transit time	For valve transit time up to 240 sec · Set point ramp for supply and exhaust air separately adjustable
Direction of action	Reversible · Set using software
Air consumption	Independent of supply air < 90 l _n /h
Air output capacity	Actuator filled: For Δp = 6 bar: 9.3 m _n ³ /h · For Δp = 1.4 bar: 3.5 m _n ³ /h Actuator vented: For Δp = 6 bar: 15.5 m _n ³ /h · For Δp = 1.4 bar: 5.8 m _n ³ /h
Permissible ambient temperature	-40 to 80 °C · Data in the EC Type Examination Certificate apply for explosion-protected devices
Effects	Temperature: ≤ 0.15 %/10 K Supply air: None Vibration: None up to 250 Hz and 4 g
Degree of protection	IP 65 with the included filter check valve
Electromagnetic compatibility	Complies with EN 61000-1-2 and EN 61000-1-3 requirements
Binary input	Internal power supply 5 V DC · R _i approx. 100 kΩ for signaling function
Forced fail-safe venting	Activated/deactivated using internal switches Input: 6 to 24 V DC · R _i approx. 6 kΩ at 24 V DC (depending on voltage) Switching point: 1-signal at ≥ 3 V · 0-signal only at 0 V · Static destruction limit 45 V K _v 0.17
Electrical connections	One M20 x 1.5 cable gland for 7 to 12 mm clamping range · Second threaded M20 x 1.5 connection additionally exists · Screw terminals for 0.2 to 2.5 mm ² wire cross-section
Communication	
Data transmission	As per FOUNDATION™ Fieldbus specification · Communication Profile Class: 31 PS, 32, Interoperability tested according to Interoperability Test System (ITS) Revision 4.0
Accessories	
Inductive limit switches	Two Type SJ2-SN Proximity Switches For connection to a NAMUR switching amplifier according to EN 60947-5-6

Table 2 · Materials and weights

Case	Die-cast aluminum, chromated and plastic coated
External parts	Stainless steel 1.4571 and 1.4301
Weight	Approx. 1.3 kg

Table 3 · Technical data for Type 3787-1...

Type	3787-1...
Type of protection For connection to fieldbus systems according to FISCO	EEx ia IIC/IIB T6 The positioner's type of protection depends on the type of protection of the intrinsically safe circuit.
FOUNDATION™ Fieldbus	
Connection	Terminals according to EN 61158-2
Operating values	According to EN 61158-2
Type of protection of the intrinsically safe circuit	EEx ia IIC/IIB The type of protection for the installed FOUNDATION™ Fieldbus depends on the type of protection of the corresponding intrinsically safe circuit.
Maximum values EEx ia IIC/EEx ib IIC EEx ia IIB/EEx ib IIB Effective internal capacitance Effective internal inductance	For connection to certified intrinsically safe circuit with: $U_i \leq 20 \text{ V} \cdot I_i \leq 285 \text{ mA}$ $U_i \leq 24 \text{ V} \cdot I_i \leq 285 \text{ mA}$ $C_i \leq 5 \text{ nF}$ $L_i \approx 0 \text{ } \mu\text{H}$
Inductive limit switches	
Connection	Terminals +41/-42 and +51/-52 · Maximum two limit switches
Type of protection of the intrinsically safe circuit	EEx ia IIC/IIB The type of protection depends on the corresponding type of protection of the intrinsically safe circuit.
Maximum values Effective internal capacitance Effective internal inductance	For connection to certified intrinsically safe circuit with: $U_i \leq 16 \text{ V} \cdot I_i \leq 52 \text{ mA} \cdot P_i \leq 169 \text{ mW}$ $C_i \leq 60 \text{ nF}$ $L_i \leq 100 \text{ } \mu\text{H}$
Forced fail-safe venting action	
Connection	Terminals +81/-82
Type of protection of the intrinsically safe circuit	EEx ia IIC/IIB The type of protection depends on the corresponding type of protection of the intrinsically safe circuit.
Maximum values Effective internal capacitance Effective internal inductance	For connection to certified intrinsically safe circuit with: $U_i \leq 28 \text{ V} \cdot I_i \leq 115 \text{ mA}$ $C_i \leq 5 \text{ nF}$ $L_i \approx 0 \text{ } \mu\text{H}$
Binary input	
Connection	Terminals +85/-86
Type of protection of the intrinsically safe circuit	EEx ia IIC/IIB The type of protection depends on the corresponding type of protection of the intrinsically safe circuit.
Maximum values Effective internal capacitance Effective internal inductance	Only for connection of a floating passive contact $U_0 \leq 5.88 \text{ V} \cdot I_0 \leq 1 \text{ mA}$ In Hazardous Area Group IIC: $C_0 \leq 43 \text{ } \mu\text{F}$ · In Hazardous Area Group IIB: $C_0 \leq 1000 \text{ } \mu\text{F}$ In Hazardous Area Group IIC: $L_0 \approx 1 \text{ H}$ · In Hazardous Area Group IIB: $L_0 \approx 1 \text{ H}$

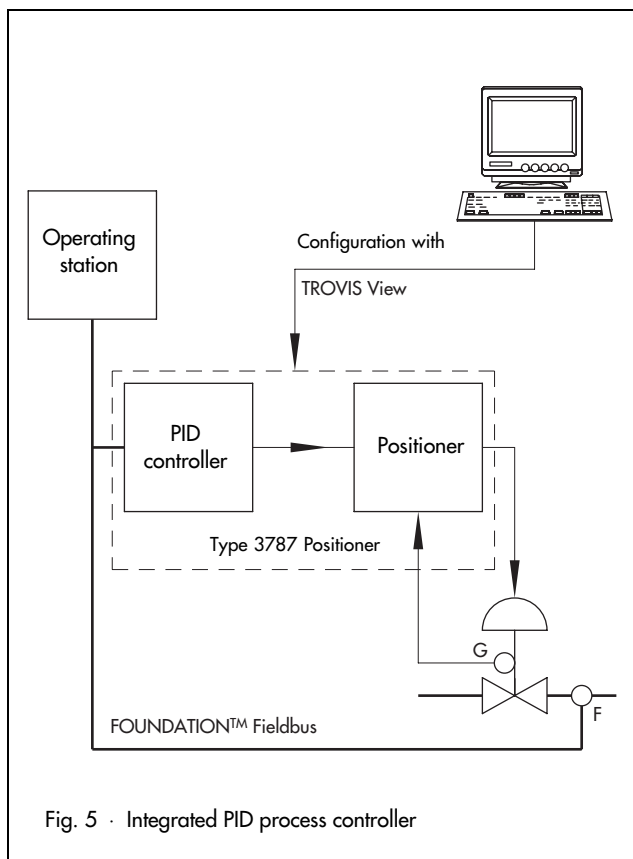

Integrated PID process controller (Fig. 5)

Decentralized control can be achieved by using the PID function block as a master controller for the positioner.

- Freely selectable controller structure (P, PI, PID controller)
- Manual, automatic or cascade operating mode
- Rating and limitation of signals
- Rating and filtering of process data
- Feedforward control
- Detection and forwarding of alarms

Network and positioner configuration with NI-FBUS™ Configurator

The positioner can also be configured using the NI-FBUS™ Configurator from National Instruments.

An interface card is required for connection to the FOUNDATION™ Fieldbus.

Using the NI-FBUS™ Configurator, the whole FOUNDATION™ Fieldbus network can be configured. It also enables the use of the PID controller in the positioner which allows autonomous control in the field.

Table 4 · Summary of explosion protection approvals

Type of approval	Certificate number	Date	Comments
Type 3787-1			
EC Type Examination Certificate First Addendum	PTB 01 ATEX 2105	2001-08-06 2004-01-14	⊕ II 2 G EEx ia IIC T6 ⊕ II 2 D IP 65 T 80 °C; Zone 21
GOST approval	2002.C299	2002-12-26	1 Ex ia IIC T6 X; valid until 2008-01-01
NEPSI approval	GYJ04482	2004-11-24	Ex ia IIC T4...T6; valid until 2009-11-23
Type 3787-8			
Statement of Conformity First Addendum	PTB 01 ATEX 2117 X	2002-04-05 2004-01-14	⊕ II 3 G EEx nA II T6; Zone 2 ⊕ II 3 D IP 65 T 80 °C; Zone 22
NEPSI approval	GYJ04483X	2004-11-24	Ex nL IIC T4...T6; valid until 2009-11-23
Type 3787-3			
CSA approval	1207872	2002-07-07	Cl. I, Div 1; Gr. A, B, C, D Cl. I, Zone 0 Ex ia IIC T6; Type 4 Enclosure
FM approval	3010779	2002-09-19	Cl. I, II, III; Div. 1; Gr. A, B, C, D, E, F, G Cl. I, Zone 0, AEx ia IIC T6 Cl. I; Div. 2; Gr. A, B, C, D; Cl. II, III; Div. 2; Gr. E, F, G Cl. III; Div. 2; NEMA Type 4X

Electrical and bus connection (Figs. 6 to 8)

The Type 3787 FOUNDATION™ Fieldbus Positioner must be connected to bus segments conforming to EN 61158-2. Power supply as well as data communication use shielded two-wire cables.

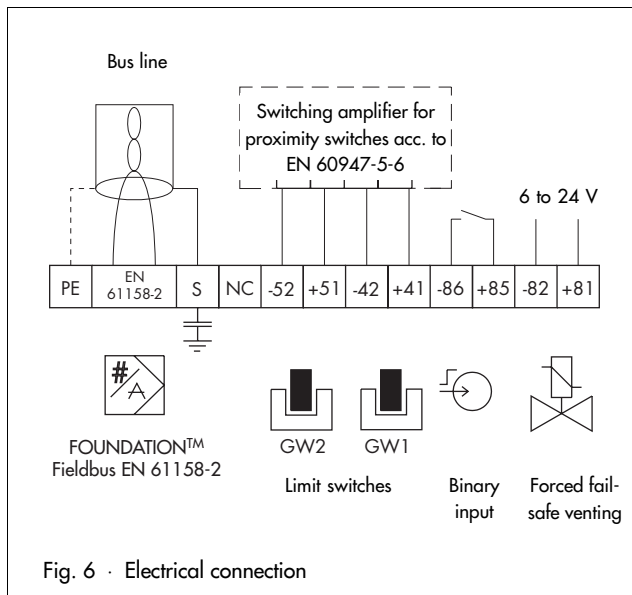

Fig. 6 · Electrical connection

Attaching the digital positioner

The Type 3787 Positioner can be attached directly to the Type 3277 Actuator using a mounting block. In actuators with the fail-safe position "Actuator stem extends" and Type 3277-5 Actuator (120 cm²), the signal pressure is led internally to the actuator through a hole inside the actuator yoke. In actuators with fail-safe action "Actuator stem retracts" and actuators with an effective area of 240 cm² and larger, the signal pressure is led to the actuator through a ready-made external piping arrangement.

The positioner can be also attached using an adapter plate conforming to IEC 60534-6 (NAMUR recommendation). The positioner can be attached on either side of the control valve.

Attachment to the Type 3278 Actuator or other rotary actuators according to VDI/VDE 3845 requires an intermediate piece. The rotary motion of the actuator is converted into a linear motion via a cam disk. This cam disk is designed for an angle of either 0° to 90° or 0° to 120°. The characteristic can be selected via software.

For double-acting springless actuators, a reversing amplifier is required for the second opposing signal pressure.

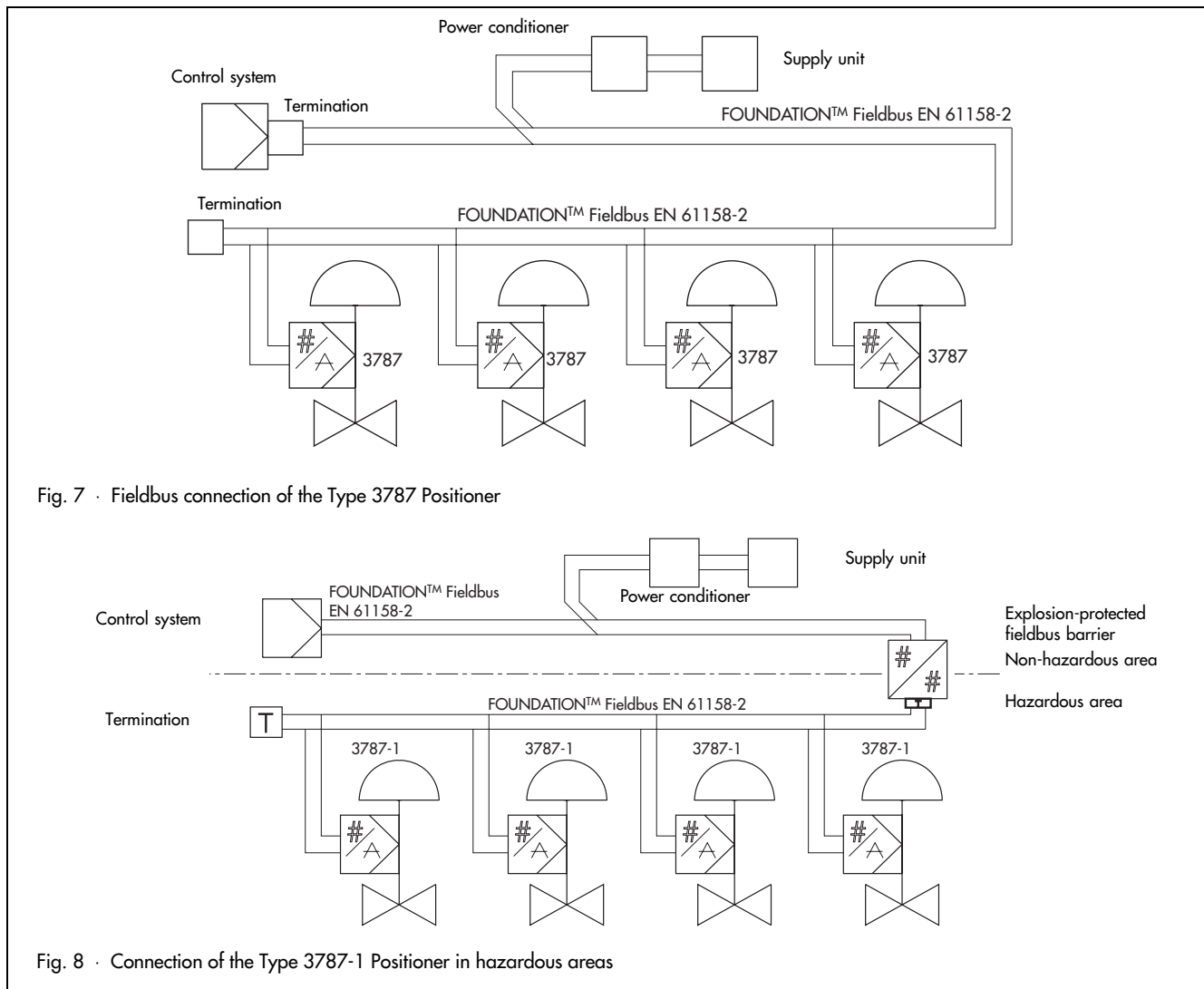
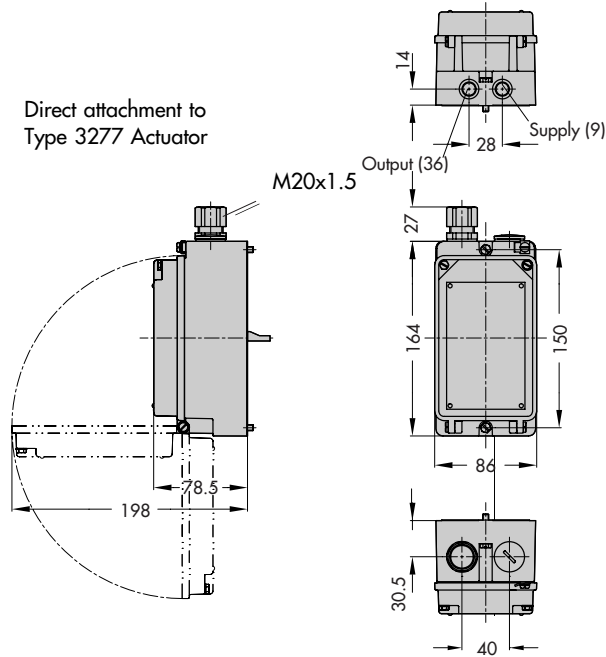

Fig. 7 · Fieldbus connection of the Type 3787 Positioner

Fig. 8 · Connection of the Type 3787-1 Positioner in hazardous areas

Dimensions in mm

Direct attachment to
Type 3277 Actuator



Attachment according to
IEC 60534-6-1 and NAMUR

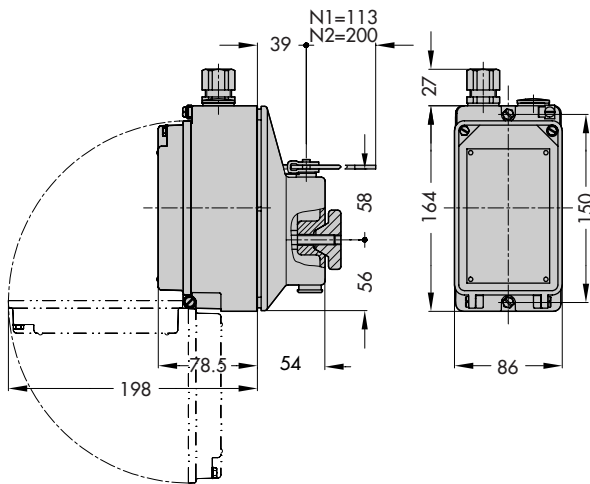

Attachment to rotary actuators
VDI/VDE 3845

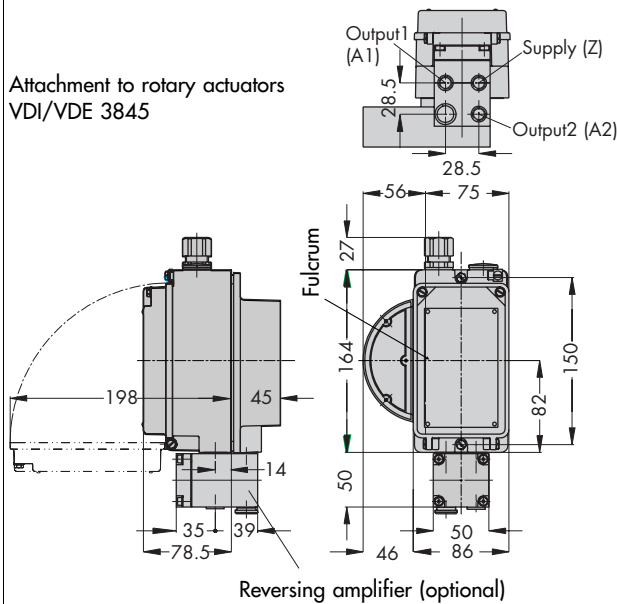

Ordering text

FOUNDATION™ Fieldbus Positioner

Type 3787-

Without/with pressure gauge to indicate signal pressure

For positioners with limit switches:

Metal tag outside of the active zone

Metal tag inside of the active zone

Attachment to Type 3277 Actuator:

Actuator sizes 120/240/350/700 cm²

Fail-safe action:

Actuator stem extends or retracts

Attachment according to IEC 60534-6-1 (NAMUR)

Travel ... mm

Stem diameter, if applicable ... mm

If applicable, signal pressure restrictions for actuators with small travel volume

Attachment to Type 3278 Rotary Actuator,

Actuator sizes 160/320 cm²

Attachment to single-acting/double-acting rotary actuators according to VDI/VDE 3845

If applicable, signal pressure restrictions for actuators with small travel volume

Specifications subject to change without notice.

Article code

Positioner	Type 3787-	x	x	x	0	x	3	x	0	0	0	0	0
Explosion protection													
Without		0											
⊕ II 2 G EEx ia IIC T6 acc. to ATEX		1											
FM/CSA Ex ia		3											
⊕ II 3 G EEx nA II T6 acc. to ATEX		8											
Limit switches													
Without			0										
2 x inductive			2					2					
Forced venting													
Without				0									
With				1				2					
Pneumatic connections													
1/4-18 NPT							1						
ISO 228/1 - G 1/4							2						
Electric connections													
1 x M20 x 1.5 metal cable gland with shielding												1	
2 x M20 x 1.5 metal cable glands with shielding												2	

